

**TURCK**

Your Global Automation Partner

# REM...|RES... Encoders with SSI Interface

Instructions for Use

# Contents

<b>1</b>	<b>About these instructions .....</b>	<b>3</b>
1.1	Target groups .....	3
1.2	Explanation of symbols .....	3
1.3	Other documents .....	3
1.4	Feedback about these instructions .....	3
<b>2</b>	<b>Notes on the product .....</b>	<b>4</b>
2.1	Product identification .....	4
2.2	Scope of delivery.....	4
2.3	TURCK service .....	4
<b>3</b>	<b>For your safety .....</b>	<b>5</b>
3.1	Intended use .....	5
3.2	Obvious misuse .....	5
3.3	General safety notes.....	5
<b>4</b>	<b>Product description .....</b>	<b>6</b>
4.1	Device overview .....	6
4.1.1	Display elements .....	6
4.2	Operating principle .....	6
4.3	Functions and operating modes .....	6
4.3.1	Output function .....	6
4.3.2	Input function.....	6
4.4	Technical accessories .....	7
<b>5</b>	<b>Installing .....</b>	<b>8</b>
5.1	Installing the solid shaft encoder .....	9
5.2	Installing the hollow shaft encoder.....	10
<b>6</b>	<b>Connection .....</b>	<b>11</b>
6.1	Wiring diagram.....	11
<b>7</b>	<b>Commissioning.....</b>	<b>12</b>
<b>8</b>	<b>Setting .....</b>	<b>13</b>
8.1	Zero setting.....	13
8.2	Setting the rotation direction.....	13
8.3	Deactivating unused inputs.....	13
<b>9</b>	<b>Troubleshooting.....</b>	<b>14</b>
<b>10</b>	<b>Maintenance .....</b>	<b>15</b>
<b>11</b>	<b>Repair .....</b>	<b>15</b>
11.1	Returning devices .....	15
<b>12</b>	<b>Disposal.....</b>	<b>15</b>
<b>13</b>	<b>TURCK branches – contact data .....</b>	<b>16</b>

# 1 About these instructions

These instructions describe the setup, functions and use of the product and help you to operate the product according to its intended purpose. Read these instructions carefully before using the product. This will prevent the risk of personal injury and damage to property. Keep these instructions safe during the service life of the product. If the product is passed on, pass on these instructions as well.

## 1.1 Target groups

These instructions are aimed at qualified personal and must be carefully read by anyone mounting, commissioning, operating, maintaining, dismantling or disposing of the device.

## 1.2 Explanation of symbols

The following symbols are used in these instructions:



### **DANGER**

DANGER indicates a hazardous situation with a high level of risk, which, if not avoided, will result in death or serious injury.



### **WARNING**

WARNING indicates a hazardous situation with a medium level of risk, which, if not avoided, will result in death or serious injury.



### **CAUTION**

CAUTION indicates a hazardous situation with a medium level of risk, which, if not avoided, will result in moderate or minor injury.



### **NOTICE**

CAUTION indicates a situation which, if not avoided, may cause damage to property.



### **NOTE**

NOTE indicates tips, recommendations and important information about special action steps and issues. The notes simplify your work and help you to avoid additional work.



### **MANDATORY ACTION**

This symbol denotes actions that the user must carry out.



### **RESULT OF ACTION**

This symbol denotes the relevant results of an action.

## 1.3 Other documents

Besides this document, the following material can be found on the Internet at [www.turck.com](http://www.turck.com):

- Data sheet
- EU Declaration of Conformity (current version)
- Quick Start Guide

## 1.4 Feedback about these instructions

We make every effort to ensure that these instructions are as informative and as clear as possible. If you have any suggestions for improving the design or if some information is missing in the document, please send your suggestions to [techdoc@turck.com](mailto:techdoc@turck.com).

## 2 Notes on the product

### 2.1 Product identification

These instructions apply to the following encoders with SSI interface:

- RES-182
- RES-183
- RES-186
- RES-187
- REM-99
- REM-100
- REM-103
- REM-104
- REM-E-118

### 2.2 Scope of delivery

The scope of delivery includes:

- Encoder – sensor
- Quick Start Guide

### 2.3 TURCK service

TURCK supports you in your projects — from the initial analysis right through to the commissioning of your application. The TURCK product database at [www.turck.com](http://www.turck.com) offers you several software tools for programming, configuring or commissioning, as well as data sheets and CAD files in many export formats.

For the contact details of our branches worldwide, please see page [▶ 16].

## 3 For your safety

The product is designed according to state of the art technology. Residual hazards, however, still exist. Observe the following safety instructions and warnings in order to prevent danger to persons and property. TURCK accepts no liability for damage caused by failure to observe these safety instructions.

### 3.1 Intended use

Encoders with an SSI interface are used to measure angular movements. To do this, the devices absorb mechanical rotary movements and convert them into electrical pulse sequences. Per revolution, a defined number of pulses is emitted.

The device must only be used as described in these instructions. Any other use is not in accordance with the intended use. TURCK accepts no liability for any resulting damage.

### 3.2 Obvious misuse

- The devices are not safety components and must not be used for personal protection.
- Any use that exceeds the maximum permissible mechanical speed (see technical data) is deemed to be not in accordance with the intended purpose.

### 3.3 General safety notes

- The device meets the EMC requirements for the industrial areas. When used in residential areas, take measures to prevent radio frequency interference.
- The device must only be fitted, installed, operated, parameterized and maintained by trained and qualified personnel.
- Only use the device in compliance with the applicable national and international regulations, standards and laws.
- If safe operation is no longer guaranteed: Take the device out of operation and ensure that it cannot be switched on again accidentally.

## 4 Product description

The encoders in the REM... and RES... product series with SSI interface are available as solid shaft or hollow shaft versions. The REM...E product series contains only solid shaft devices. Devices are available in three different sizes, ranging from 36 to 100 mm.

The SSI encoders output the absolute angular position in RS485 format.

### 4.1 Device overview

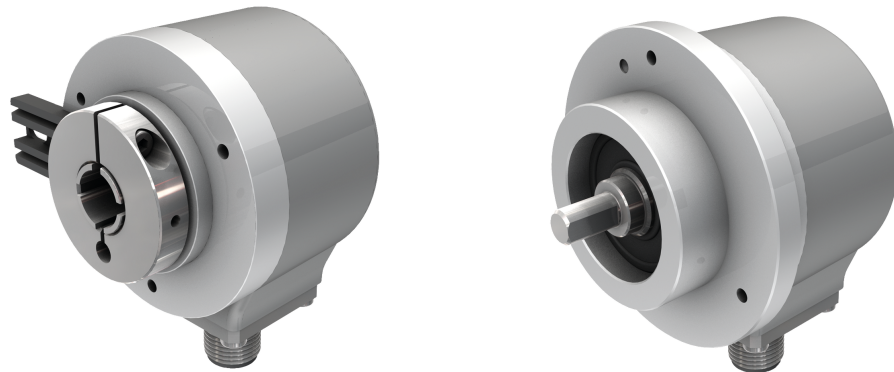

Fig. 1: Example — encoder with hollow shaft    Fig. 2: Example — encoder with solid shaft

#### 4.1.1 Display elements

The device has two LED displays.

### 4.2 Operating principle

Encoders detect rotational movements, such as the angle velocity of a shaft. Encoders convert the rotational movements into electrical signals. The devices pass on the electrical signals to a higher-level controller for evaluation. Encoders are designed as absolute and incremental encoders with hollow or solid shafts.

Absolute encoders also supply the angle value after a startup if the value has changed when deactivated. Incremental encoders only detect position changes when active by counting periodic patterns. This normally involves the optical scanning of a rotating disk.

### 4.3 Functions and operating modes

#### 4.3.1 Output function

The output signal of the encoders with SSI interface is based on the RS485 protocol with a permissible load of max.  $\pm 20$  mA. The clock rate is 50 kHz...2 MHz.

If the clock cycle starts within the monoflop time, a second data transfer starts with the same data. When the clock cycle starts after the monoflop time, the cycle starts with new values. The update rate depends on the clock speed, the data length, and the monoflop time.

#### 4.3.2 Input function

The encoder has a SET input and a DIR input. The inputs can be adjusted by short-circuiting (see Setting [▶ 13](#)). The response time of the inputs is 1 ms.

The number of write cycles for the SET input is limited to 10,000.

## 4.4 Technical accessories

Dimension drawing	Type	ID	Description
	E-RKC 8T-264-2	U-04781	Connection cable; M12 female connector, straight, 8-pin, cable length 2 m, jacket material: PVC, black; other cable lengths and types available, see <a href="http://www.turck.com">www.turck.com</a>

## 5 Installing



### NOTICE

Incorrect mounting

#### Risk of damage to the sensor

- ▶ Do not modify or disassemble the encoder.
- ▶ Do not make adjustments to the shaft after mounting.
- ▶ Do not use a hammer to align the device.
- ▶ Avoid impact loads.
- ▶ Load the encoder shaft only within the permissible values (see technical data).
- ▶ Do not rigidly connect the rotary encoder to shafts and flanges at the same time. Use the coupling between the drive shaft and the encoder shaft or the hollow shaft encoder flange.

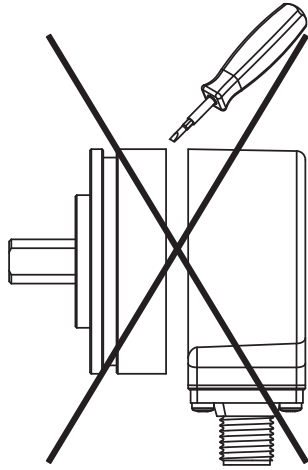

Fig. 3: Mounting view — do not open

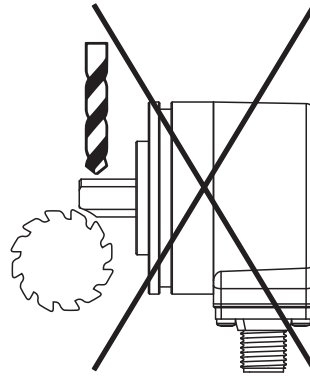

Fig. 4: Mounting view — do not make adjustments after mounting

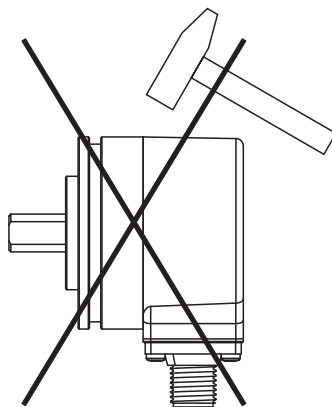

Fig. 5: Mounting view — do not use a hammer to align the device

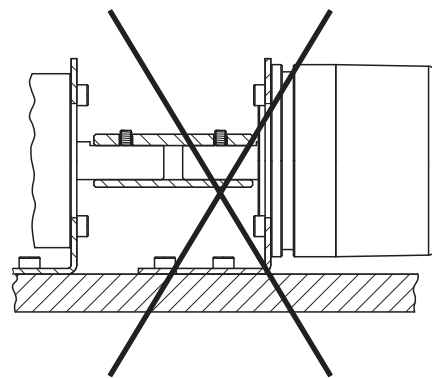

Fig. 6: Mounting view — do not rigidly connect the device to shafts and flanges at the same time

## 5.1 Installing the solid shaft encoder

- ▶ Check shaft for displacement.
- ▶ Refer to the technical data for the coupling for the maximum axial displacement, radial displacement, and angular displacement values.

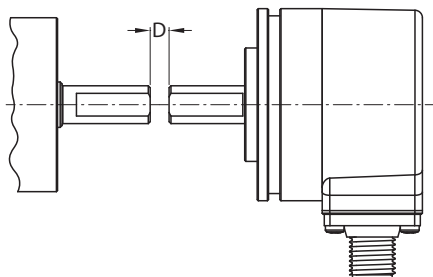

Fig. 7: Axial displacement

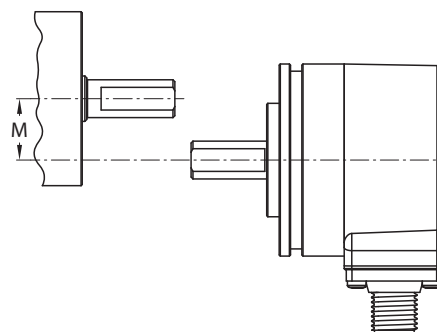

Fig. 8: Radial displacement

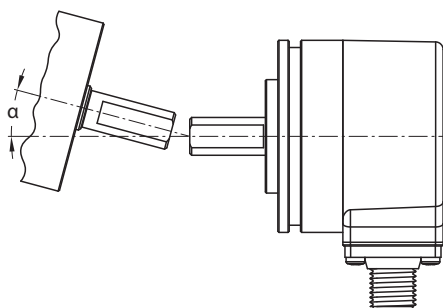

Fig. 9: Angular displacement

- ▶ During mounting, protect the coupling against excessive bending and damage.
- ▶ Align the coupling on the shaft.
- ▶ Secure the coupling on the device using tensioning screws or clamping screws. For the maximum tightening torque, refer to the data sheet of the screws used.

## 5.2 Installing the hollow shaft encoder

- ▶ Slide the encoder onto the shaft.

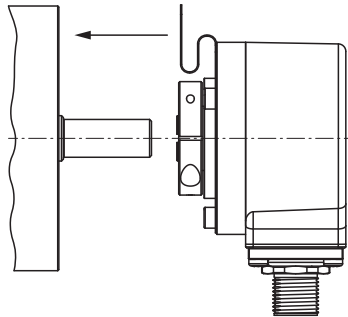

Fig. 10: Sliding the encoder onto the shaft

- ▶ Screw the female connector to the drive flange.

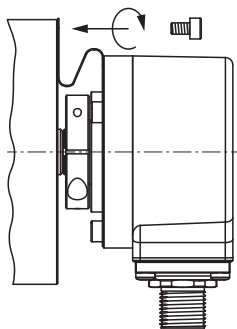

Fig. 11: Screwing the female connector to the drive flange

- ▶ Tighten the clamping hub by hand.

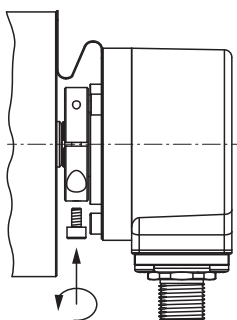

Fig. 12: Tightening the clamping hub

## 6 Connection

The encoder is provided with an 8-pin M12 × 1 male connector with an SSI interface. Refer to the sensor label or data sheet for the pin layout.



### CAUTION

Connecting and disconnecting during operation  
**Device damage possible**

- ▶ Only connect the device when it is in a de-energized state.

TURCK recommends the following cable lengths:

- For asymmetrical transmission (no inverted signals): max. 10 m
  - For symmetrical transmission (e.g. RS422 standard): max. 50 m with twisted pairs
- ▶ Connect all required cable cores as per the wiring diagram. Insulate the cable ends that are not required to avoid short circuits.
  - ▶ Follow the operating instructions for the connecting cable used.
  - ▶ Disconnect the encoder from the connecting cable only when the encoder is de-energized.
  - ▶ Connect the shielding (if present) to the encoder housing.
  - ▶ The encoder and processor must always be switched on and off simultaneously.
  - ▶ Observe the operating voltage and maximum permissible output current (see technical data).

### EMC-compliant installation

- ▶ Use shielded connection cables as control cables.
- ▶ For symmetrical transmission (e.g. via RS422): Use twisted pair cables.
- ▶ Connect protective earth to the rotary encoder and the evaluation unit (low impedance).
- ▶ Route the connection cables separately from cables with high noise levels.
- ▶ Do not connect devices with high noise levels to the encoder's power supply (e.g. frequency converters, solenoid valves, or contactors), or ensure that suitable voltage filtering is in place.

### 6.1 Wiring diagram

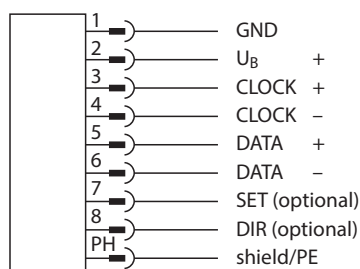

Fig. 13: Encoder REM SSI | RES SSI — Wiring diagram

## 7 Commissioning

The device is operational automatically 150 ms after the connection is made and the power supply is switched on.

## 8 Setting

### 8.1 Zero setting



#### **NOTE**

Only set the zero point when the device is at a standstill.

---

- ▶ Move the application with the mounted encoder to the desired position.
- ▶ Short-circuit pin 2 (UB) with pin 7 (SET) for at least 10 ms.
- ⇒ The zero point is set after 200 ms.

### 8.2 Setting the rotation direction

In the factory setting, the device is set to operate clockwise (CW). The direction of rotation can be inverted as follows:

- ▶ Permanently short-circuit pin 2 (UB) with pin 8 (DIR).
- ⇒ The direction of rotation is set to counterclockwise (CCW).

### 8.3 Deactivating unused inputs

- ▶ Connect unused inputs to GND (0 V) in order to prevent interference.

## 9 Troubleshooting

If the device does not function as expected, first check whether ambient interference is present. If there is no ambient interference present, check the connections of the device for faults.

If there are no faults, there is a device malfunction. In this case, decommission the device and replace it with a new device of the same type.

If the device does not work as expected, proceed as follows:

- ▶ Exclude environmental disturbances.
- ▶ Check the connections of the device for errors.
- ▶ Check device for parameterization errors.

If the malfunction persists, the device is faulty. In this case, decommission the device and replace it with a new device of the same type.

## 10 Maintenance

Ensure regularly that the plug connections and cables are in good condition.

The devices are maintenance-free, clean dry if required.

## 11 Repair

The device is not intended for repair by the user. The device must be decommissioned if it is faulty. Observe our return acceptance conditions when returning the device to TURCK.

### 11.1 Returning devices

If a device has to be returned, bear in mind that only devices with a decontamination declaration will be accepted. This is available for download at <https://www.turck.de/en/return-service-6079.php> and must be completely filled in, and affixed securely and weather-proof to the outside of the packaging.

## 12 Disposal



The devices must be disposed of properly and do not belong in the domestic waste.

## 13 TURCK branches – contact data

<b>Germany</b>	TURCK GmbH Witzlebenstraße 7, 45472 Mülheim an der Ruhr <a href="http://www.turck.de">www.turck.de</a>
<b>Australia</b>	Turck Australia Pty Ltd Building 4, 19-25 Duerdin Street, Notting Hill, 3168 Victoria <a href="http://www.turck.com.au">www.turck.com.au</a>
<b>Austria</b>	Turck GmbH Graumanngasse 7/A5-1, A-1150 Vienna <a href="http://www.turck.at">www.turck.at</a>
<b>Belgium</b>	Turck Multiprox N. V. Lion d'Orweg 12, B-9300 Aalst <a href="http://www.multiprox.be">www.multiprox.be</a>
<b>Brazil</b>	Turck do Brasil Automação Ltda. Rua Anjo Custódio Nr. 42, Jardim Anália Franco, CEP 03358-040 São Paulo <a href="http://www.turck.com.br">www.turck.com.br</a>
<b>Canada</b>	Turck Canada Inc. 140 Duffield Drive, CDN-Markham, Ontario L6G 1B5 <a href="http://www.turck.ca">www.turck.ca</a>
<b>China</b>	Turck (Tianjin) Sensor Co. Ltd. 18,4th Xinghuazhi Road, Xiqing Economic Development Area, 300381 Tianjin <a href="http://www.turck.com.cn">www.turck.com.cn</a>
<b>Czech Republic</b>	TURCK s.r.o. Na Brne 2065, CZ-500 06 Hradec Králové <a href="http://www.turck.cz">www.turck.cz</a>
<b>France</b>	TURCK BANNER S.A.S. 11 rue de Courtalin Bat C, Magny Le Hongre, F-77703 MARNE LA VALLEE Cedex 4 <a href="http://www.turckbanner.fr">www.turckbanner.fr</a>
<b>Hungary</b>	TURCK Hungary kft. Árpád fejedelem útja 26-28., Óbuda Gate, 2. em., H-1023 Budapest <a href="http://www.turck.hu">www.turck.hu</a>
<b>India</b>	TURCK India Automation Pvt. Ltd. 401-403 Aurum Avenue, Survey. No 109 /4, Near Cummins Complex, Baner-Balewadi Link Rd., 411045 Pune - Maharashtra <a href="http://www.turck.co.in">www.turck.co.in</a>
<b>Italy</b>	TURCK BANNER S.R.L. Via San Domenico 5, IT-20008 Bareggio (MI) <a href="http://www.turckbanner.it">www.turckbanner.it</a>
<b>Japan</b>	TURCK Japan Corporation ISM Akihabara 1F, 1-24-2, Taito, Taito-ku, 110-0016 Tokyo <a href="http://www.turck.jp">www.turck.jp</a>

<b>Korea</b>	Turck Korea Co, Ltd. A605, 43, Iljik-ro, Gwangmyeong-si 14353 Gyeonggi-do <a href="http://www.turck.kr">www.turck.kr</a>
<b>Malaysia</b>	Turck Banner Malaysia Sdn Bhd Unit A-23A-08, Tower A, Pinnacle Petaling Jaya, Jalan Utara C, 46200 Petaling Jaya Selangor <a href="http://www.turckbanner.my">www.turckbanner.my</a>
<b>Mexico</b>	Turck Comercial, S. de RL de CV Blvd. Campestre No. 100, Parque Industrial SERVER, C.P. 25350 Arteaga, Coahuila <a href="http://www.turck.com.mx">www.turck.com.mx</a>
<b>Netherlands</b>	Turck B. V. Ruiterlaan 7, NL-8019 BN Zwolle <a href="http://www.turck.nl">www.turck.nl</a>
<b>Poland</b>	TURCK sp.z.o.o. Wroclawska 115, PL-45-836 Opole <a href="http://www.turck.pl">www.turck.pl</a>
<b>Romania</b>	Turck Automation Romania SRL Str. Siriului nr. 6-8, Sector 1, RO-014354 Bucuresti <a href="http://www.turck.ro">www.turck.ro</a>
<b>Sweden</b>	Turck AB Fabriksstråket 9, 433 76 Jonsered <a href="http://www.turck.se">www.turck.se</a>
<b>Singapore</b>	TURCK BANNER Singapore Pte. Ltd. 25 International Business Park, #04-75/77 (West Wing) German Centre, 609916 Singapore <a href="http://www.turckbanner.sg">www.turckbanner.sg</a>
<b>South Africa</b>	Turck Banner (Pty) Ltd Boeing Road East, Bedfordview, ZA-2007 Johannesburg <a href="http://www.turckbanner.co.za">www.turckbanner.co.za</a>
<b>Turkey</b>	Turck Otomasyon Ticaret Limited Sirketi Inönü mah. Kayisdagi c., Yesil Konak Evleri No: 178, A Blok D:4, 34755 Kadiköy/ Istanbul <a href="http://www.turck.com.tr">www.turck.com.tr</a>
<b>United Kingdom</b>	TURCK BANNER LIMITED Blenheim House, Hurrricane Way, GB-SS11 8YT Wickford, Essex <a href="http://www.turckbanner.co.uk">www.turckbanner.co.uk</a>
<b>USA</b>	Turck Inc. 3000 Campus Drive, USA-MN 55441 Minneapolis <a href="http://www.turck.us">www.turck.us</a>

# TURCK

Your Global Automation Partner

Over 30 subsidiaries and  
60 representations worldwide!

100009124 | 2025/12



[www.turck.com](http://www.turck.com)